



Design and Development of Hybrid Power Generation for Smart Grid

Darshan J¹, Dr. J S Rajashekar²

PG Student, Department of Electronics & Instrumentation Engineering, Dayananda Sagar College of Engineering,
Bangalore, India¹

Associate Professor, Department of Electronics & Instrumentation Engineering, Dayananda Sagar College of
Engineering, Bengaluru, India²

Abstract: The objective of the project work is to control and study the simulation of hybrid (solar and wind power) renewable energy system connected to the grid. The system includes a photovoltaic panel, synchronous permanent magnet generator based wind turbine, and a battery for storage energy. The PV array and wind systems are connected to the common DC bus by a boost converter. The battery is connected by a bi-directional DC/DC converter, and then integrated into the AC utility grid via a common DC/AC inverter. In order to extract the maximum energy, a simulation study has been carried out according to the meteorological conditions (wind speed and variable solar irradiance) while maintaining power quality at a satisfactory level. In order to capture the maximum power, a MPPT algorithm is applied for both wind turbine and photovoltaic panel. The modeling and simulation of the whole system has been performed under Matlab/Simulink environment. The obtained results show that the current and the voltage of grid side are sinusoidal and alternative forms, and the power injected to the grid is around the power produced by the hybrid system.

Keywords: Photovoltaic cell (PV cell), Wind Turbine (WT), Hybrid Energy Power System (HEPS).

I. INTRODUCTION

The increase in the demand for electric power is due to population growth and economic development. Currently the world is looking for energy alternative source due to demand for electricity. The renewable energy is more and more attractive due to its environmental protection. The renewable energy source has been unpredictable random behavior. The hybrid renewable energy systems are becoming most popular for generation of power. However some of the renewable energy sources like solar radiation and wind speed have complementary profile. It has been found that in small or weak power grids, the solar and wind hybrid system is better than a single solar or wind generation. Grid interface of the hybrid system with battery storage improves the system reliability and efficiency. The maximum power point tracking method is used to extract the maximum power from the both solar and wind power generation. The modeling and simulation of the solar and wind are carried out in the matlab/simulink. The Madhav Singh Thakur, BhupendraGupta, Veerendra Kumar. Mukesh Pandey, "Renewable Hybrid Energy System for Sustainable and Economical Power Supply- A Review" International Journal of Eng. Research & Technology (IJERT)[1] have proposed a hybrid power generation system suitable for remote area application. The concept of hybridizing renewable energy sources is that the base load is to be covered by largest and firmly available renewable source and other intermittent source should augment the base load to cover the peak load of an isolated mini electric grid system. Seul-Ki Kim, Eung-Sang Kim and Jong-Bo Ahn, "Modeling and Control of a grid connected wind/PV hybrid generation system", Transmission and Distribution conference and Exhibition [2], Dallas, TX deals with power control of a wind and solar hybrid generation system for interconnection operation with electric distribution system. The proposed system consists of a variable-speed direct-drive wind generator, wind-side converter, solar array, dc-dc converter and grid interface inverter. Power control strategy is to extract the maximum energy available from varying condition of wind speed and solar irradiance while maintaining power quality at a satisfactory level. In order to capture the maximum power, variable speed control is employed for wind turbine and maximum power point tracking is applied for photovoltaic system.

JitendraKasera, Ankit Chaplot, Jai Kumar Maherchandani, "Modeling and Simulation of Wind-PV Hybrid Power System using MATLAB/Simulink", IEEE Students' Conference on Electrical, Electronics and Computer Science (SCEECS)[3] presents the modeling of a PV-wind hybrid system in Matlab/Simulink.



The model is useful for simulation of a hybrid PV-wind system connected to a grid. Blocks like wind model, PV model, energy conversion and load are implemented and the results of simulation are also presented.

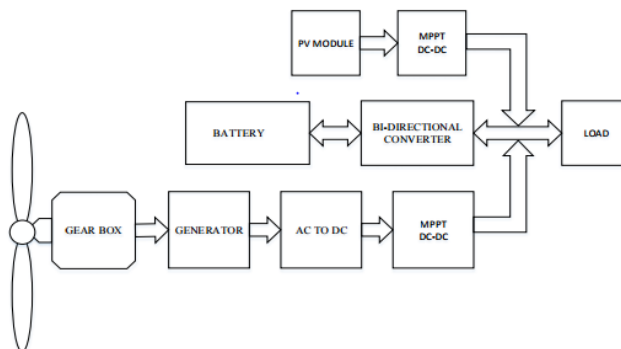

Figure 1. Block diagram of hybrid system

"Modelling and Analysis of MPPT Techniques for Grid Connected PV Systems", International journal of Innovative Research in Electrical, Electronics, Instrumentation and Control Engineering, YoI.2,issue2 [4] evaluates the most commonly used MPPT techniques and finds which MPPT technique is most suitable for grid connected systems. The modelling of a Photovoltaic cell, dc to dc converter, and simulation study of a grid connected PV system. The Fei Ding, Peng Li, Bibin Huang, Fei Gao, Chengdi Ding, Chengshan Wang, " Modeling and Simulation of Grid-connected Hybrid Photovoltaic/Battery Distributed Generation System", International conference on Electricity Distribution [5] presents detailed transient models of the grid-connected PV/Battery hybrid generation system, and all these models are simulated by using MATLAB/Simulink. PV array is firstly connected to the common dc bus by a boost converter, where the battery is also connected by a bi-directional DC/DC converter, and then integrated into the ac utility grid by a common DC/AC inverter. Maximum power point tracking helps PV array to generate the maximum power to the grid, and the battery energy storage can be charged and discharge to balance the power between PV generation and utility grid. Finally, different cases are simulated, and the results have verified the validity of models and control schemes. Harini. M, Ramaprabha R. and Mathur B. L, "Modeling of grid connected hybrid wind/pv generation system using Matlab", Asian Research Publishing Network (ARPN) Journal of Engineering and Applied Sciences [6] presents the modeling of grid connected hybrid wind-solar photovoltaic (PV) system. The proposed system consists of wind generator, wind-side converter, solar PV array, dc-dc converter, and grid interface inverter. Maximum Power Point Tracking (MPPT) is important in solar PV system, because they maximize the output power from the PV system so that effective PV array utilization.

II. PHOTOVOLTAIC CELL MODELING

The photovoltaic cell is made up of semiconductor material, which is specially treated to form an electric field. The photovoltaic array is defined as the group of several cells connected in series and parallel combination to generate the required current and voltage. Based on the static behavior of the conventional PN junction diode we will propose a photovoltaic model. The equivalent circuit of the photovoltaic cell is shown in below figure 1. This PV model consist of a direct current generator I_{ph} in parallel with a diode and shunt resistance R_{sh} and series resistor R_s .

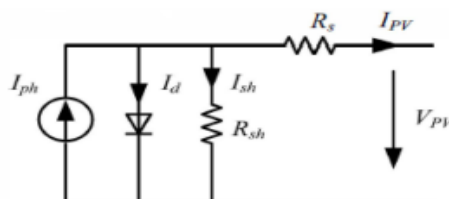

Figure 2. PV cell equivalent circuit

The output current can be expressed as:

$$I_{pv} = I_{ph} - I_d - I_{sh} \dots \dots \dots (1)$$



Where I_{PV} is the load current, I_{ph} is the photocurrent proportional to sunlight intensity, I_d is the diode current and I_{sh} is the PV cells leakage current. The current flowing through the diode can be given by:

$$I_d = I_o \{ \exp [q (V_{pv} + I_{pv} R_s) / A k T] - 1 \} \dots\dots\dots (2)$$

Where I_o is the reverse saturation current of diode, q is the electronic charge, k is the Boltzmann constant, T is the absolute temperature (K) and A is the ideality factor of PN junction.

$$I_{sh} = (V_{pv} + I_{pv} R_s) / R_{sh} \dots\dots\dots (3)$$

Then (1) can be written as:

$$I_{pv} = I_{ph} - I_o \{ \exp [q (V_{pv} + I_{pv} R_s) / A k T] - 1 \} - (V_{pv} + I_{pv} R_s) / R_{sh} \dots\dots\dots (4)$$

$$V_{pv} = V_d - I_{pv} R_s \dots\dots\dots (5)$$

$$I_d = I_{sat} [\exp (V_d / V_T) - 1] \dots\dots\dots (6)$$

$$V_T = k * T / q * A * N_{cell} * N_{ser} \dots\dots\dots (7)$$

Where V_d is the diode voltage (V), I_{so} is the current of saturation of diode (A), V_T is technique voltage (V), N_{cell} is number of cellule connected in series by module, N_{ser} is number of module connected in series by string. The parameters of the solar panel is given in the below table.

Parameters	Values
Short circuit current(A)	$I_{sc} = 8.5$
Open circuit voltage(v)	$V_{oc} = 30.6$
Number of cells per module	$n_{Cell} = 50$
Number of series connected modules per string	$N_{ser} = 0.5$
Number of parallel strings	$N_p = 1$
Maximum current(A)	$I_m = 7.83$
Maximum voltage(V)	$V_m = 24.3$
Parallel resistance(ohms)	$R_p = 766.7$
Series resistance(ohms)	$R_s = 0.175$
Diode saturation current(A)	$I_{sat} = 2.89e^{-7}$
Light-generation photo current(A)	$I_{ph} = 8.5156$
Diode Quality factor	$A = 1.5$

A.Series resistance

In a parallel PV cell, there is a series of resistance in a current path through the semiconductor material, the metal grid, contacts, and current collecting bus. These resistive losses are lumped together as a series resistance(R_s). It effect becomes very conspicuous in a PV module that consists of many series-connected cells and the values of resistance is multiplied by the number of cells.

B.Parallel Resistance

Parallel resistance is a loss which is associated with the small leakage current through a resistive path in parallel with the intrinsic device. Parallel resistance is also called as shunt resistance. Its effect is less conspicuous in a PV module when compared to series resistance. The parallel resistance will only be noticed when a number of PV modules are connected in parallel for a larger system. Based on this assumption we can say that the solar cell is more accurate.

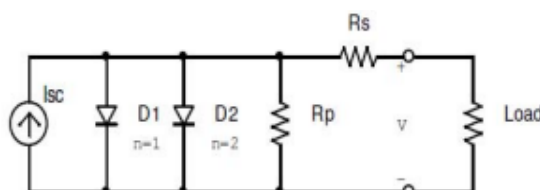

Figure 3. Accurate model of solar cell.



Due to the variation of atmospheric condition the output power of the photovoltaic cell is variable. To extract the maximum power from the solar panel under environmental conditions we are introducing a MPPT algorithm method. The MPPT algorithm which we are using is incremental conductance method. The flow chart of the incremental conductance method is demonstrated in above figure 4.

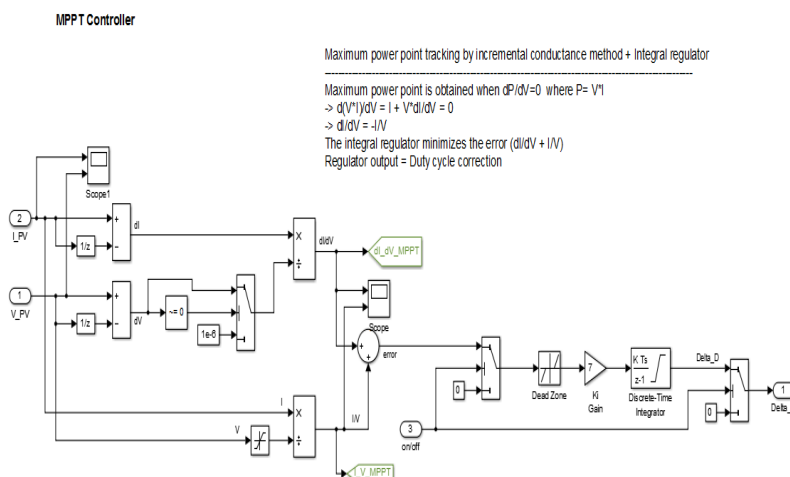

Figure 4. MPPT controller method

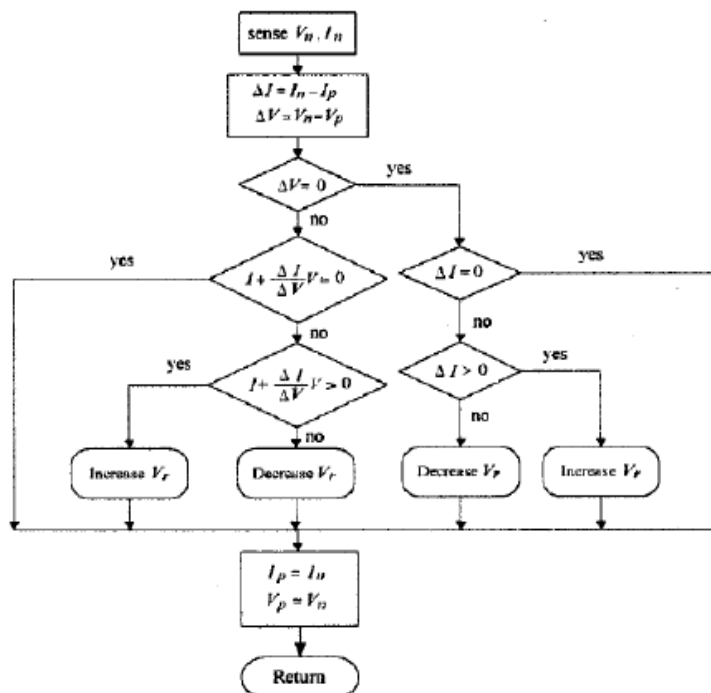

Figure 5. Flow chart of incremental conductance method

The MPP can thus be tracked by comparing the instantaneous conductance (I/V) to the incremental conductance ($\Delta I/\Delta V$). The increment size determines how fast the MPP is tracked. This method requires high sampling rates and fast calculations of power slope.

$dP/dV = 0$, at MPP
 $dP/dV > 0$, left of MPP
 $dP/dV < 0$, right of MPP
 $dP/dV = d(I \cdot V)/dV$



$$= I+V \frac{dI}{dV}$$

$$= I+V \frac{\Delta I}{\Delta V}$$

$$\Delta I/\Delta V = -I/V,$$

$$\Delta I/\Delta V > -I/V,$$

$$\Delta I/\Delta V < -I/V$$

at MPP
left of MPP
right of MPP.

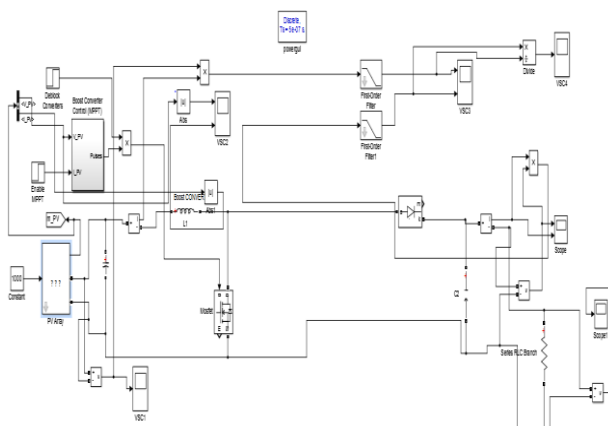

Figure 6. Complete modeling of photovoltaic cell.

III. WIND POWER GENERATION

In the Nile city to navigate the ships the first wind power was used. In 1700's and 1800's to pump the water and grind grains the European peoples were using the wind power. In US the first wind mills was installed to generate the electricity. On the Howard knob mountain at 1979 the wind turbine which is connected to grid was generating a power of 2 MW. In 1988 on the Berger Hills the 3 MW wind turbine generator was installed. In first the electricity which was developed was not directly connected to the grid. The electricity was using to lightings in the building. In worldwide the wind power capacity is about 39,294 MW in 2003 and in India the wind power generation is about 1,550 MW.

The wind turbine which converts the wind's kinetic energy into rotational motion. To match the generator speed and the wind turbine speed a gear box is placed. The generator is used to convert the mechanical energy into electricity. The rectifier is placed to convert ac voltage into dc voltage. To extract the maximum power from the wind turbine MPPT method is introduced.

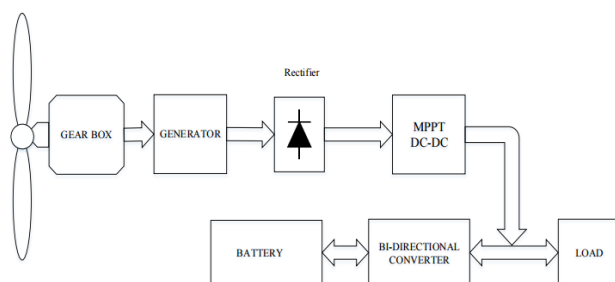

Figure 7. Wind turbine generator

The power generated from the wind turbine turbine blades is concomitant of the blade shape, the pitch angle, the radius of the rotor and speed of rotation. The equation for the wind power generated is given by

$$P_m = \frac{1}{2} \pi \rho C_p(\lambda, \beta) R^2 V^3 \dots\dots\dots 8$$

Where

P_m = power captured by wind turbine

ρ = air density

β = pitch angle (in degree)



R = blade radius (in meters)

V = wind speed (in m/s)

The term λ is the tip-speed ratio, given by

$$\lambda = \frac{\Omega R}{V} \dots\dots\dots 9$$

where

Ω = rotor speed of rotation (in radian per second)

Cp can be expressed as the function of tip-speed ratio (λ)

$$C_p = \frac{1}{2} \left(\frac{116}{\lambda^1} - 0.4\beta - 5 \right) \exp \frac{-16.5}{\lambda^1}$$

$$\lambda_1 = \frac{1}{\frac{1}{(\lambda+0.089)} - \frac{0.035}{(\beta^3+1)}} \dots\dots\dots 10$$

where,

Cp = wind turbine power coefficient

λ = tip-speed ratio

λ1 = constant

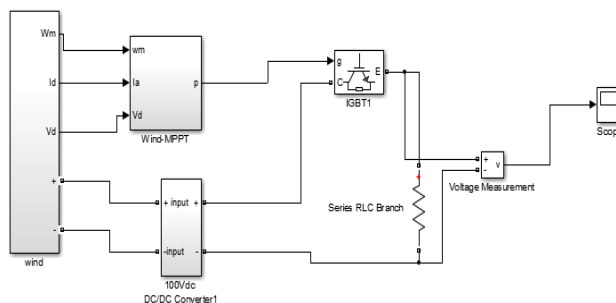

Figure 8. Complete simulink modeling of wind power.

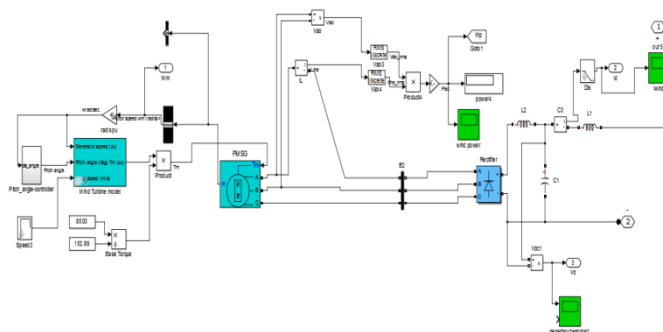

Figure 9. The wind turbine simulink modeling.

IV. CONCLUSION

In this paper, we clearly presented the design and development of the hybrid power system that comprises the photovoltaic cell and wind turbine connected to smart grid. The battery storage system is used as a backup source. The objective of this hybrid power system is to supply the power to the residential load. The detailed modeling and simulation of the hybrid power system has been carried out under the Matlab/ Simulink. By this we can interface two or more power generation sources and we can run to our requirements.

Future work to reduce the cost and minimize size of the hybrid power system, we need to optimize the photovoltaic cell and wind turbine. In the night time the solar power will not be available so, we can use the fuel cell and the battery storage system as a backup source.



ACKNOWLEDGEMENT

Author owes an intellectual debt to the reference materials, which helped achieve sound knowledge about the topic and it would also make an excellent compilation for further reading on the topic. Author would like to thank **Dr. J S Rajashekar**, Associate Professor Department of Electronics and Instrumentation Engineering, DSCE, Bengaluru for his guidance on conducting this study.. I sincerely acknowledge the encouragement and impetus given to me by my HOD, **Dr. V.G. Sangam**, Professor & Head of the Department of Electronics and Instrumentation Engineering, for their constant encouragement and support.

REFERENCES

- [1] Madhav Singh Thakur, BhupendraGupta, Veerendra Kumar. Mukesh Pandey, "Renewable Hybrid Energy System for Sustainable and Economical Power Supply- A Review" International Journal of Eng. Research & Technology (IJERT) Vol. I Issue 6, August - 2015.
- [2] Seul-Ki Kim, Eung-Sang Kim and Jong-Bo Ahn, "Modeling and Control of a grid connected wind/PV hybrid generation system", Transmission and Distribution conference and Exhibition 2005/2006 IEEE PES, pp. 1202 - 1207 , 21-24 May 2013, Dallas, TX
- [3] JitendraKasera, Ankit Chaplot, Jai Kumar Maherchandani, "Modeling and Simulation of Wind-PV Hybrid Power System using MATLAB/Simulink", IEEE Students' Conference on Electrical, Electronics and Computer Science (SCEECS), 1-2 March 2015.
- [4] Rakesh.R,Kannan.S.A,JomyJoy,Kamala.Devi. V,J ayaraju.M, "Modelling and Analysis of MPPT Techniques for Grid Connected PV Systems", International journal of Innovative Research in Electrical, Electronics, Instrumentation and Control Engineering, Yo1.2,issue2, Feruary 2014.
- [5] Fei Ding, Peng Li, Bibin Huang, Fei Gao,ChengdiDingl, Chengshan Wangl," Modeling and Simulation of Grid-connected Hybrid Photovoltaic/Battery Distributed Generation System", International conference on Electricity Distribution (CICED), 2013, China .
- [6] Harini. M, Ramaprabha R. and Mathur B. L, "Modeling of grid connected hybrid wind/pv generation system using Matlab", Asian Research Publishing Network (ARPN) Journal of Engineering and Applied Sciences, Yo1.7, No. 9, September 2014.
- [7] Belkaid, A., Gaubert, J.-P., Gherbi, A., Rahmani, L. "Maximum Power Point tracking for photovoltaic systems with boost converter sliding mode control", 23rd International Symposium on Industrial Electronics (ISIE); 1-4 June 2015, pp. 556-561, Istanbul Turkey.

BIOGRAPHY

Darshan J M.Tech in Microeletronics and Control System Engineering from Dayananda Sagar College of Engineering Bangalore.